

Tentative Subdivision Map No. 4 of The Villages at Sierra Vista:
VILLAGES CO-01, CO-02, CO-03, CO-20, CO-21 AND CO-22

A PORTION OF SECTIONS 35 AND 36, T. 11 N., R. 5 E., M.D.M.

City of Roseville,
 Scale 1" = 200'

State of California
 June 2021

Sheet 1 of 14

Project Address - 3871 Santucci Boulevard
 Project No. PL21-0223

VILLAGE ANALYSIS:

VILLAGE	LAND USE	ZONING	ACRES	UNITS	MIN. LOT SIZE	CUT / FILL	DENSITY
CO-01	LDR (Residential)	RS/DS	17.2 (16.3 NET)	87	55x100'	34,100 / 34,100	5.3 PER NET ACRE
CO-02	LDR (Residential)	RS/DS	9.9 (8.8 NET)	43	55x100'	41,460 / 41,460	4.3 PER NET ACRE
CO-03	LDR (Residential)	RS/DS	17.3 (15.7 NET)	67	60x100' MIN.	59,240 / 59,240	4.3 PER NET ACRE
CO-20	MDR (Residential)	RS/DS	14.1 (12.7 NET)	94	45x80'	72,100 / 72,100	7.4 PER NET ACRE
CO-21	MDR (Residential)	RS/DS	27.4 (25.4 NET)	193	45x80'	71,900 / 71,900	7.6 PER NET ACRE
CO-22	LDR (Residential)	RS/DS	5.9 (4.8 NET)	32	45x80'	50,770 / 50,700	6.6 PER NET ACRE
TOTAL				516		329,570 / 329,570	

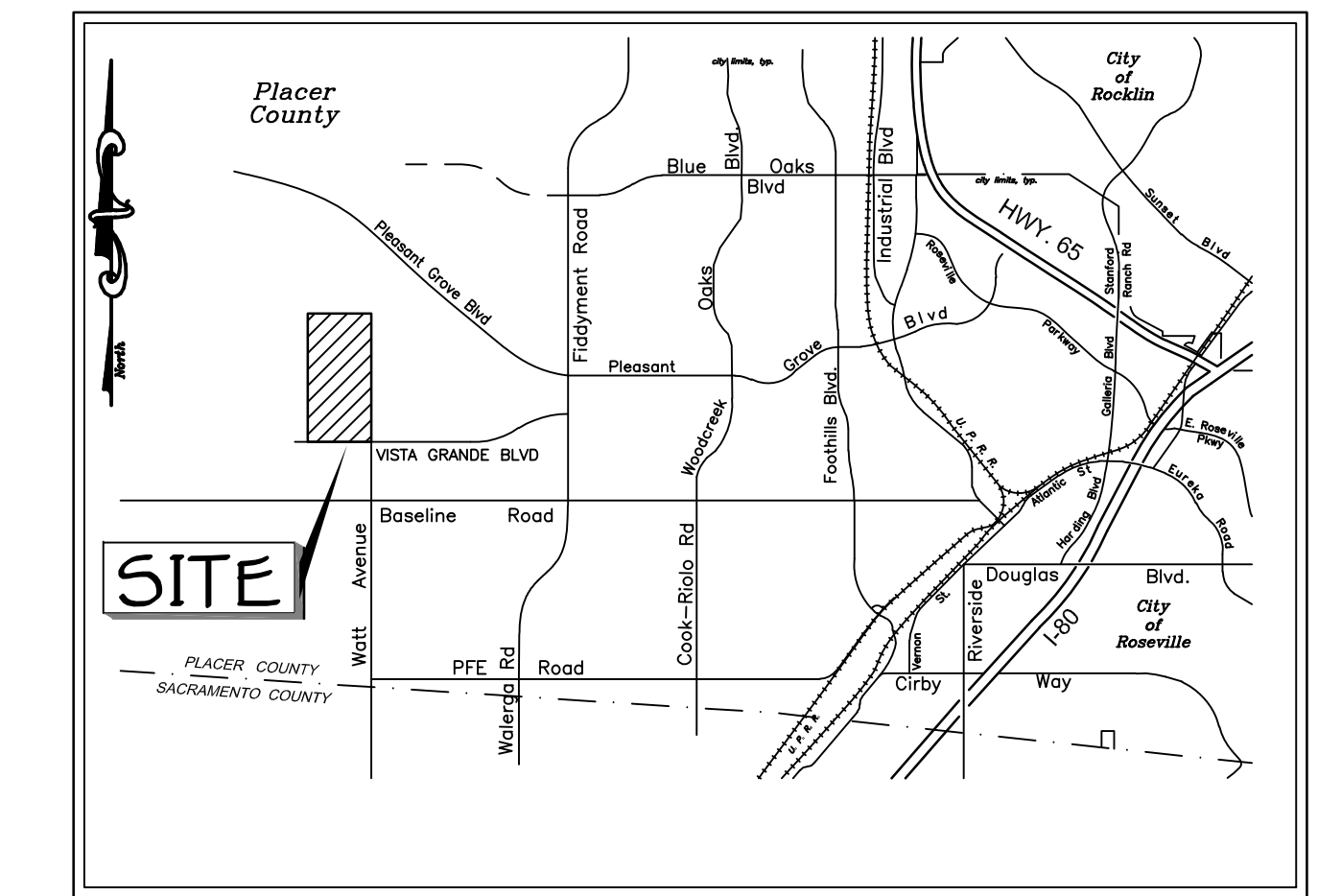

VICINITY MAP

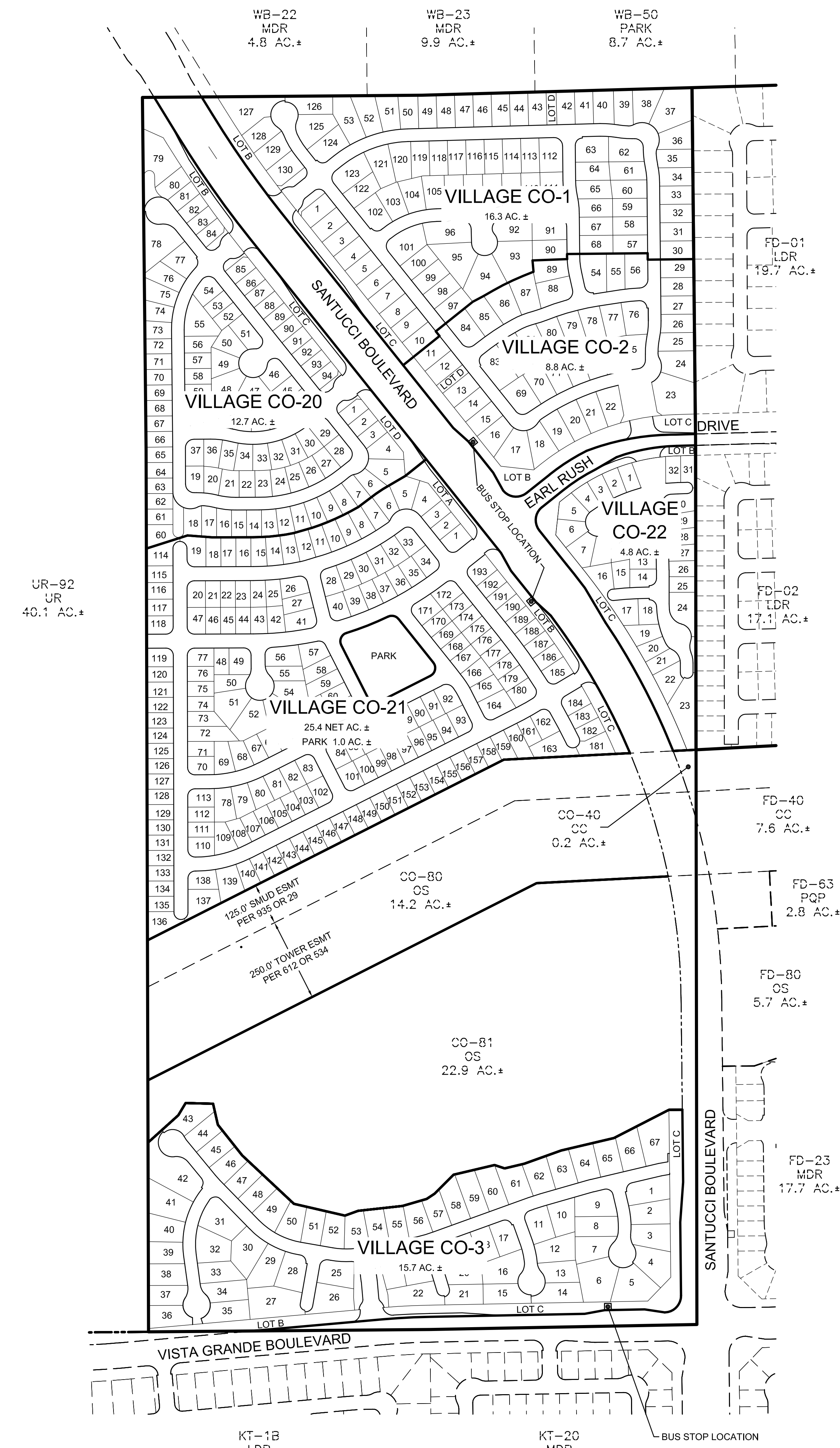

- OWNERS:**
 MOURIER INVESTMENTS, LLC
 1430 BLUE OAKS BOULEVARD, SUITE 190
 ROSEVILLE, CA 95747
 PH. (916) 969-2842
- DEVELOPER:**
 JOHN MOURIER CONSTRUCTION, INC.
 1430 BLUE OAKS BOULEVARD, SUITE 190
 ROSEVILLE, CA 95747
 PH. (916) 969-2842
- ENGINEER:**
 BAKER-WILLIAMS ENGINEERING GROUP
 6020 RUTLAND DRIVE, SUITE 119
 CARMICHAEL, CALIFORNIA, 95608
 PH. (916) 331-4336
- ASSESSOR'S PARCEL NUMBER:**
 499-010-005 THRU 009, 499-010-024, 499-010-025,
 499-010-033 THRU 055
- ACREAGE:**
 146.5 ACRES ±
- PROPOSED IMPROVEMENTS:**
 AS REQUIRED BY THE CITY OF ROSEVILLE
 DEPARTMENT OF PUBLIC WORKS
- EXISTING USE:**
 FARMHOUSE
- SEWER:**
 CITY OF ROSEVILLE
- WATER SUPPLY:**
 CITY OF ROSEVILLE
- DRAINAGE:**
 CITY OF ROSEVILLE
- FIRE PROTECTION:**
 CITY OF ROSEVILLE
- SCHOOL DISTRICT:**
 ROSEVILLE SCHOOL DISTRICT
 CENTER UNITED SCHOOL DISTRICT
- PARK DISTRICT:**
 ROSEVILLE PARKS DISTRICT

LEGEND

NAME	EXISTING	PROPOSED
MANHOLE	○	●
SANITARY SEWER PIPE	---18" S.S.---	---18" S.S.---
STORM DRAIN PIPE	---18" S.D.---	---18" S.D.---
WATER PIPE	---12" W.---	---12" W.---
DROP INLET	□	□
FIRE HYDRANT	⊕	⊕
MASONRY RETAINING WALL	---	---
FENCE	---	---
SWALE	---	---
CONTOUR	~	~
EDGE OF PAVEMENT	---	---
CURB, GUTTER & SIDEWALK	---	---
RIGHT-OF-WAY	---R/W---	---R/W---
CENTER LINE	---	---
PROPERTY LINE	---	---
SLOPE BANK	Y Y Y	Y Y Y
TOP BACK OF WALK ELEVATION		178.0
SPOT ELEVATION	178.0	222.50
PAV. GRADE		221.0
DRAINAGE DIRECTION FLOW		---

LAND USE ANALYSIS:

PARCEL	GENERAL PLAN LAND USE	ZONING	ACRES/SPECIFIC PLAN	ACRES/TENTATIVE MAP	ALLOCATED UNITS	PROPOSED UNITS	AVAILABLE UNITS	DENSITY/SPECIFIC PLAN	DENSITY/TENTATIVE MAP
CO-01	LDR (Residential)	RS/DS	17.3	17.2 (16.3 NET)	86	87	-1	5.3 PER NET ACRE	5.3 PER NET ACRE
CO-02 A & B	LDR (Residential)	RS/DS	29.8	9.9 (8.8 NET)	144	43	+101	4.9 PER NET ACRE	4.9 PER NET ACRE
CO-03	LDR (Residential)	RS/DS	15.7	17.3 (15.7 NET)	78	67	+11	5.0	4.3 PER NET ACRE
CO-20	MDR (Residential)	RS/DS	9.4	14.1 (12.7 NET)	84	94	-10	9.0	7.4 PER NET ACRE
CO-21	MDR (Residential)	RS/DS	7.8	27.4 (25.4 NET)	62	193	-131	9.0	7.6 PER NET ACRE
CO-22	LDR (Residential)	RS/DS	4.8	5.9 (4.8 NET)	38	32	+6	9.0	6.6 PER NET ACRE
CO-40	CC (Commercial)	CC	0.2						
CO-50	PR (Park Site)	PR	1.0						
CO-70 (& 71)	OS (Paseo)	OS	0.8						
CO-80	OS	OS	14.2						
CO-81	OS	OS	22.6						
JM-01	MDR (Residential)	RS/DS	16.9	17.2 (17.1 NET)	135	134	+1	7.9	7.9 PER NET ACRE
JM-20	MDR (Residential)	RS/DS	34.7	34.7 (33.8 NET)	322	271	+51	7.8	8.0 PER NET ACRE
FD-07	MDR (Residential)	RS/DS	8.5	8.5 (8.3 NET)	57	58	-1	6.4	7.0 PER NET ACRE
FD-24	MDR (Residential)	RS/DS	17.3	17.3 (16.4 NET)	84	135	-51	8.1	8.2 PER NET ACRE
FD-32A	HDR	R1	8.7		3.8	78	-78	20.5	20.5 PER NET ACRE
FD-32B	HDR	R1	4.2		4.2	116	62		27.4 PER NET ACRE
FD-41	CC/MU (Commercial Mixed Use)	CC	5.7		6.2	40	0	7.0	0.0
TOTALS			215.4	212.2	1,308	1,308	0		

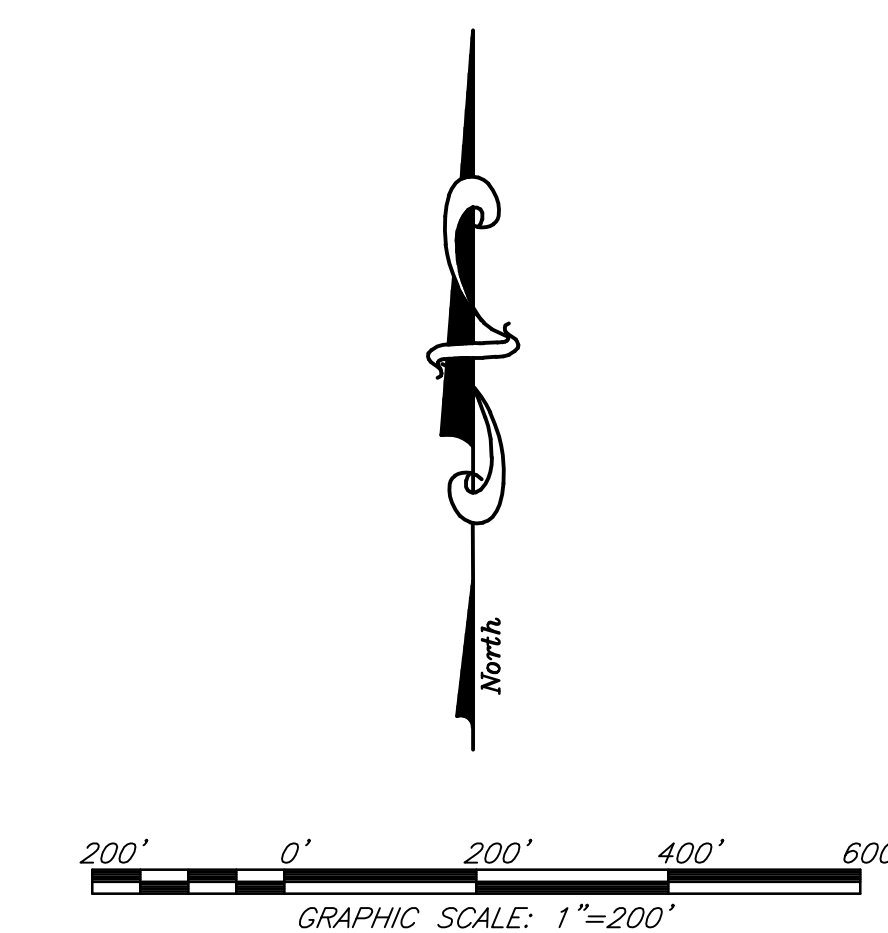

JMC HOMES
 JOHN MOURIER CONSTRUCTION INC.
 1430 Blue Oaks Blvd. Ste 190
 Roseville, Ca 95747-7143
 Office: 916-782-8879 Fax: 916-960-5322
 CALIFORNIA LIC. 613004 B

BW BAKER-WILLIAMS ENGINEERING GROUP
 Engineering / Surveying / Land Planning / Entitlement Processing / GPS Services
 6020 Rutland Drive, Suite 119 - Carmichael, CA 95608
 (916) 331-4336 - fax (916) 331-4430 - office@bwengineering.com

Tentative Subdivision Map No. 4 of The Villages at Sierra Vista:
VILLAGES CO-01, CO-02, CO-03, CO-20, CO-21 AND CO-22

A PORTION OF SECTIONS 35 AND 36, T. 11 N., R. 5 E., M.D.M.
 City of Roseville, State of California
 Scale 1" = 50'

Sheet 3 of 14

Project Address - 3871 Santucci Boulevard

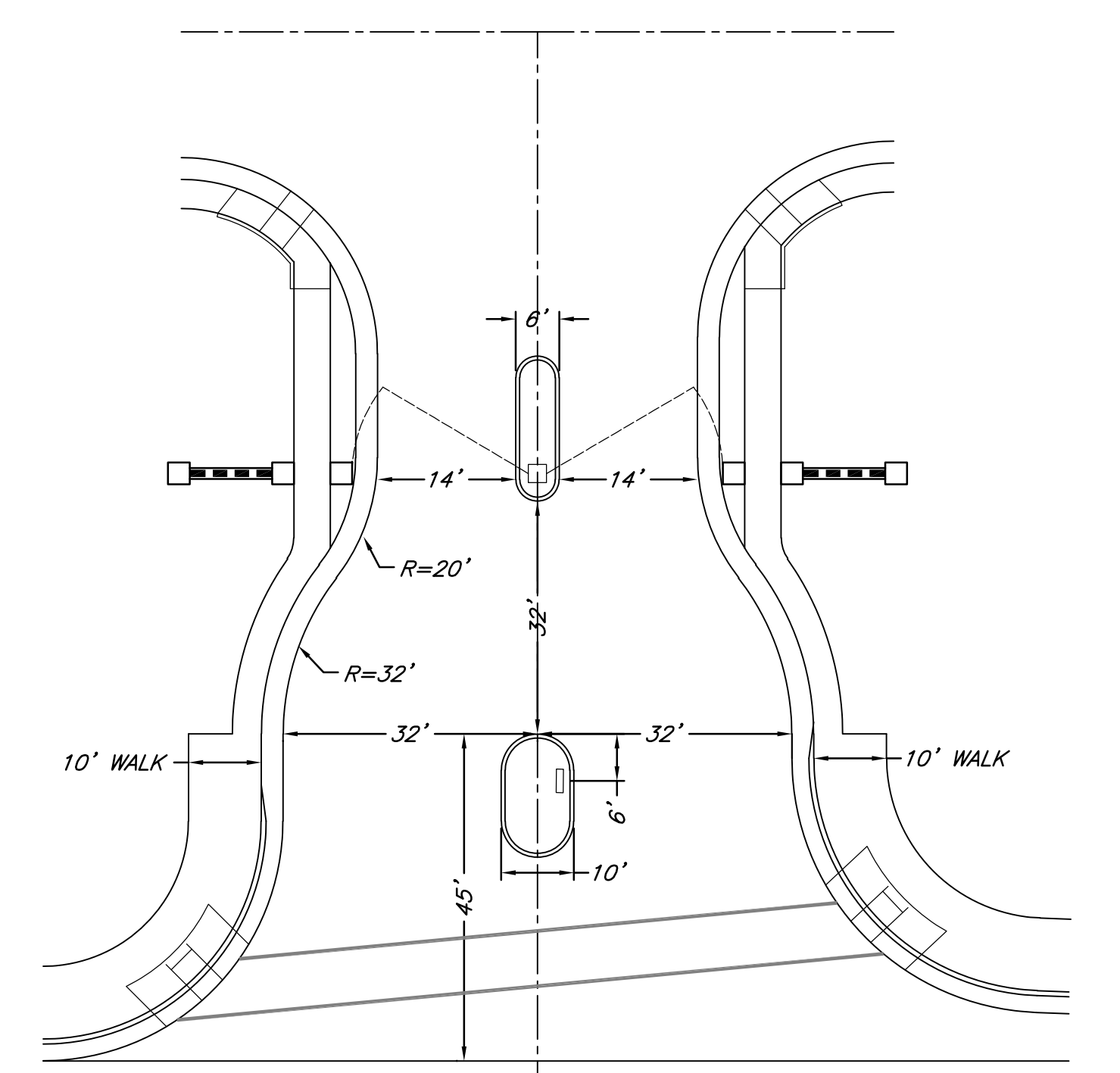
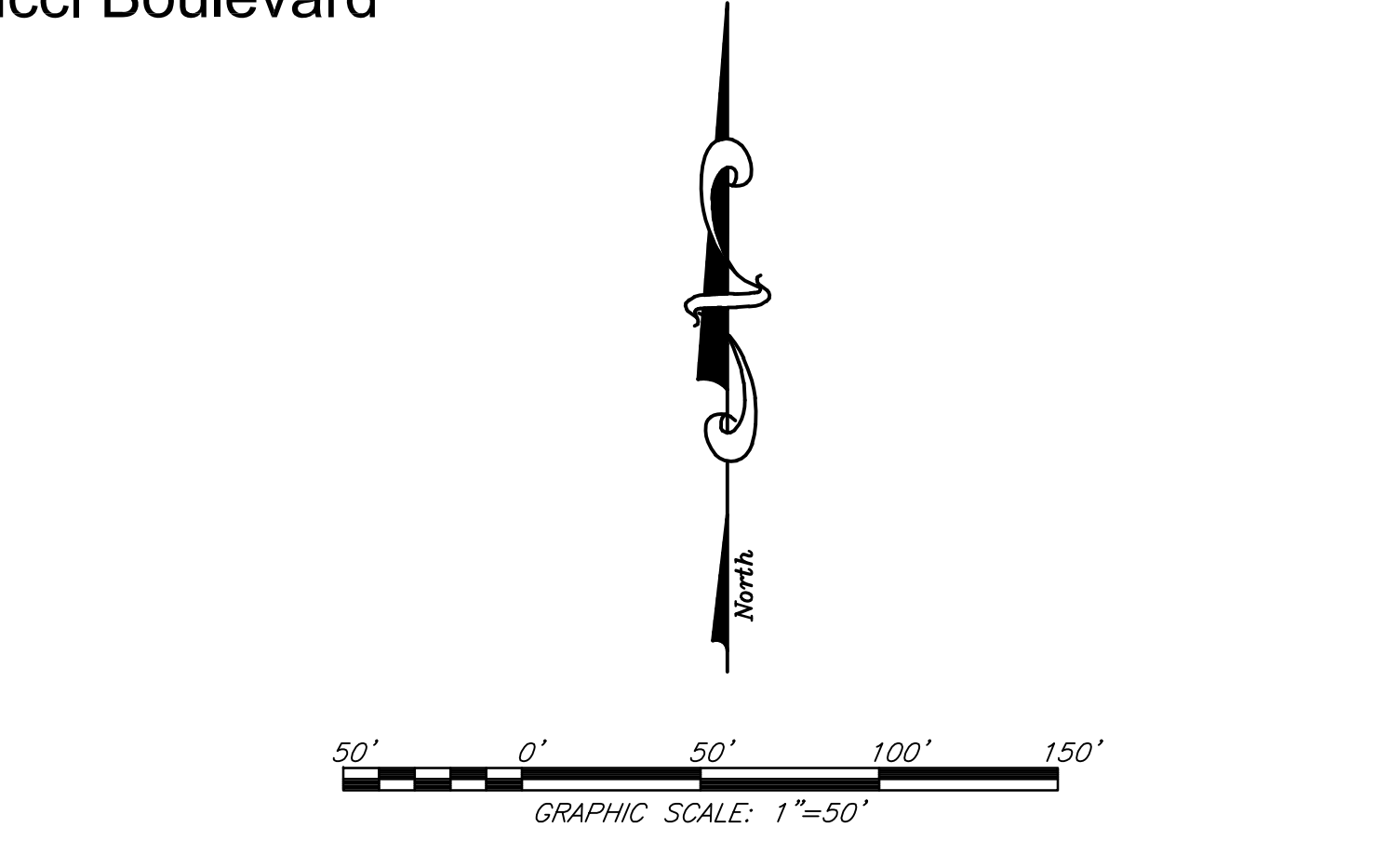

TYPICAL GATED ENTRY
 NOT TO SCALE

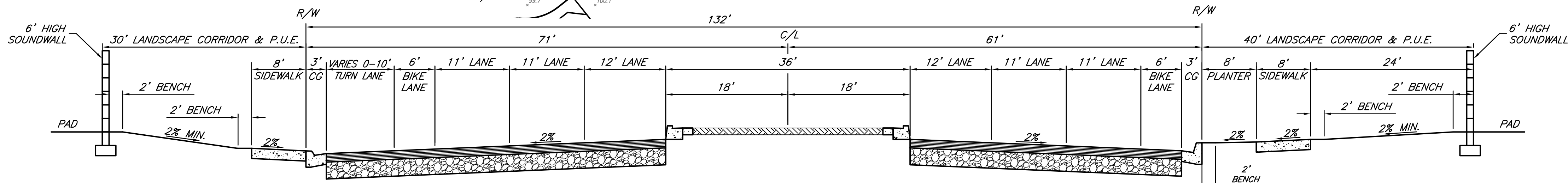

SANTUCCI BLVD. - TURN LANES LEFT
 NO SCALE

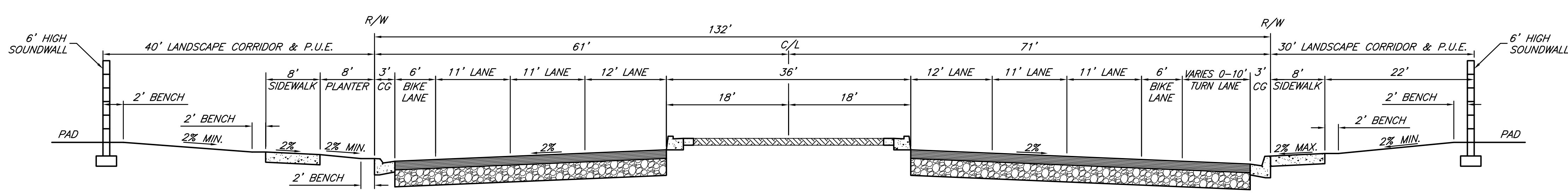

SANTUCCI BLVD. - TURN LANES RIGHT
 NO SCALE

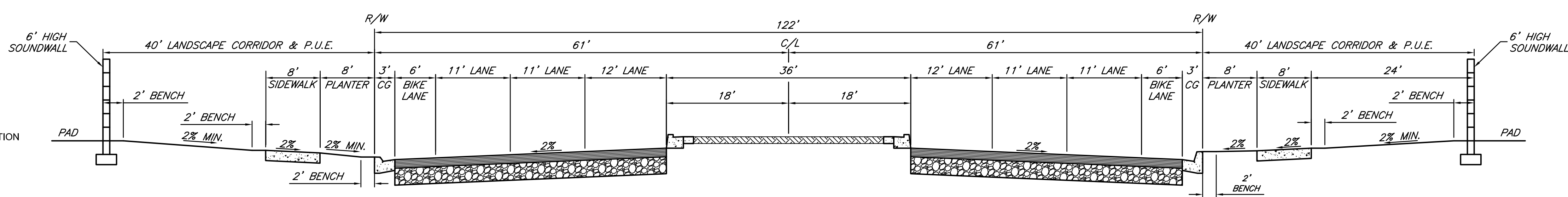

SANTUCCI BLVD.
 NO SCALE

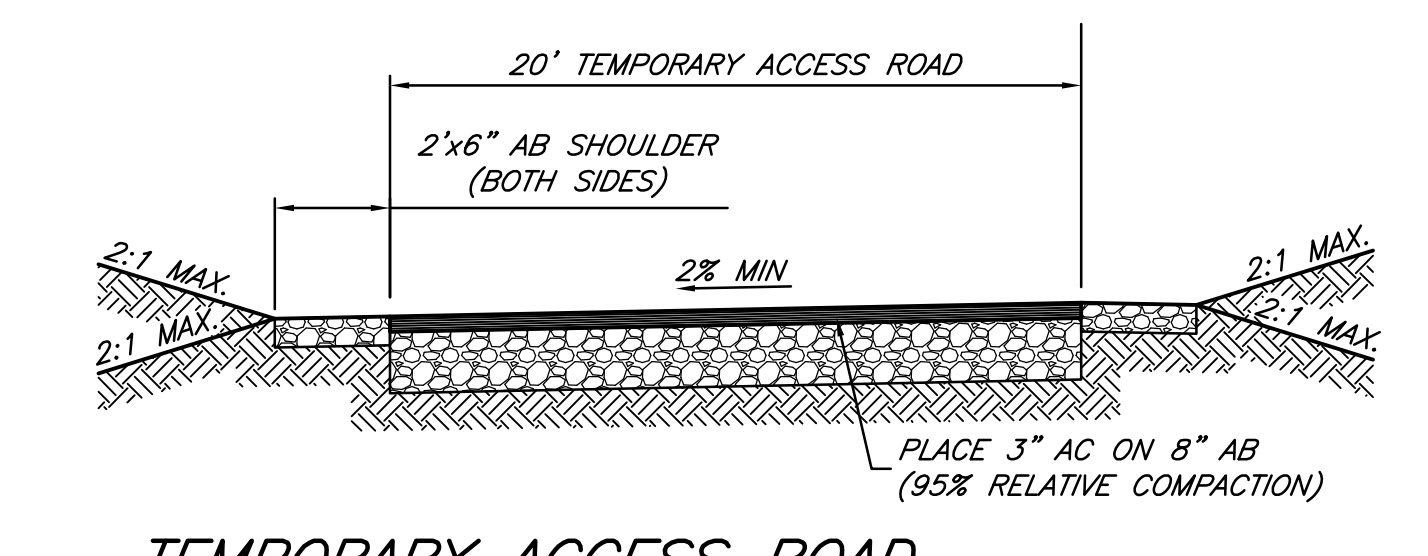

TEMPORARY ACCESS ROAD
 NO SCALE

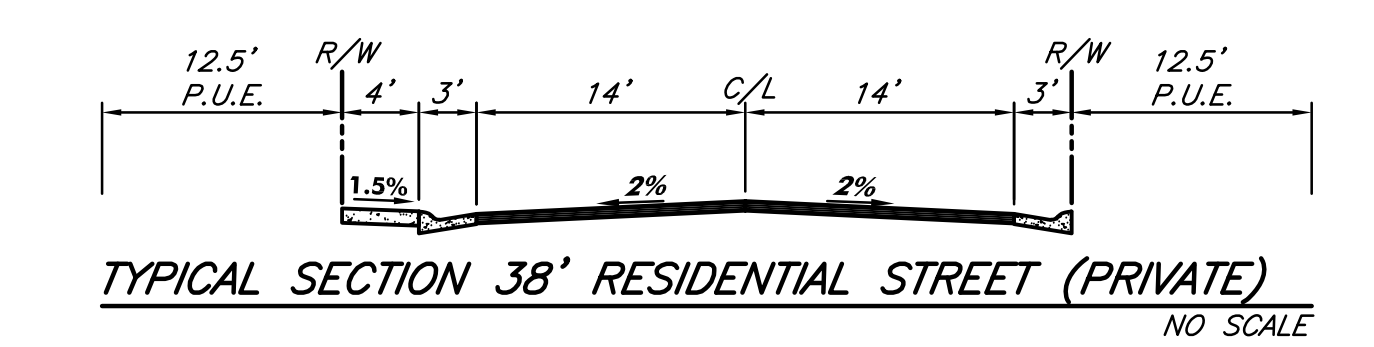

TYPICAL SECTION 38' RESIDENTIAL STREET (PRIVATE)
 NO SCALE

- NOTES: LETTERED LOTS
- LOT A PRIVATE STREET TO BE DEDICATED TO THE HOMEOWNERS ASSOCIATION
 - LOT B PUBLIC LANDSCAPE STRIP TO BE DEDICATED TO CITY OF ROSEVILLE
 - LOT C PUBLIC LANDSCAPE STRIP TO BE DEDICATED TO CITY OF ROSEVILLE
 - LOT D OPEN SPACE TO BE DEDICATED TO THE CITY OF ROSEVILLE

Tentative Subdivision Map No. 4 of The Villages at Sierra Vista:
VILLAGES CO-01, CO-02, CO-03, CO-20, CO-21 AND CO-22

A PORTION OF SECTIONS 35 AND 36, T. 11 N., R. 5 E., M.D.M.

City of Roseville,
 Scale 1" = 50'

State of California
 June 2021

Sheet 5 of 14

Project Address - 3871 Santucci Boulevard

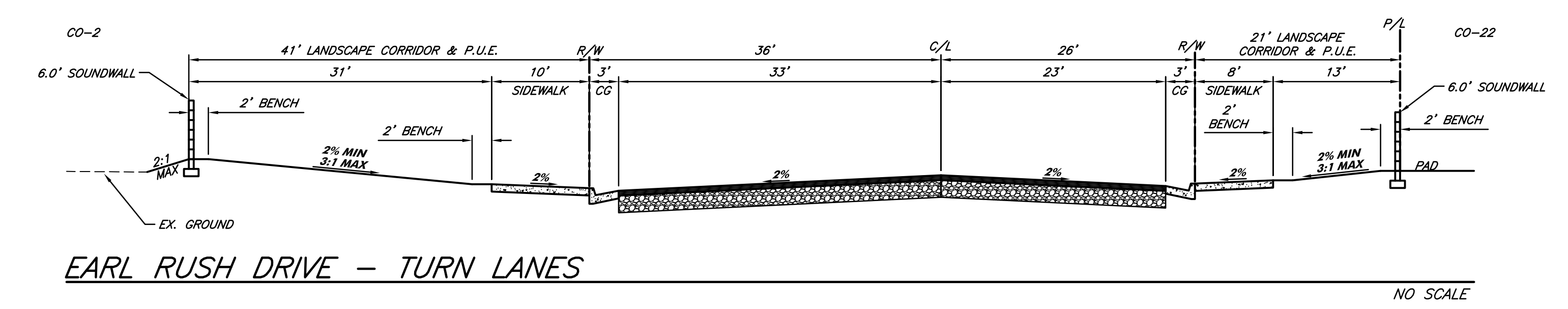
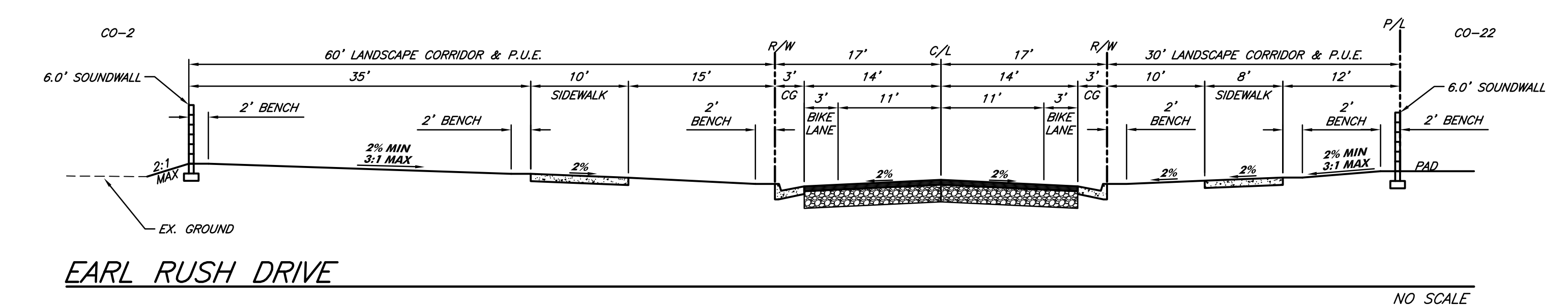
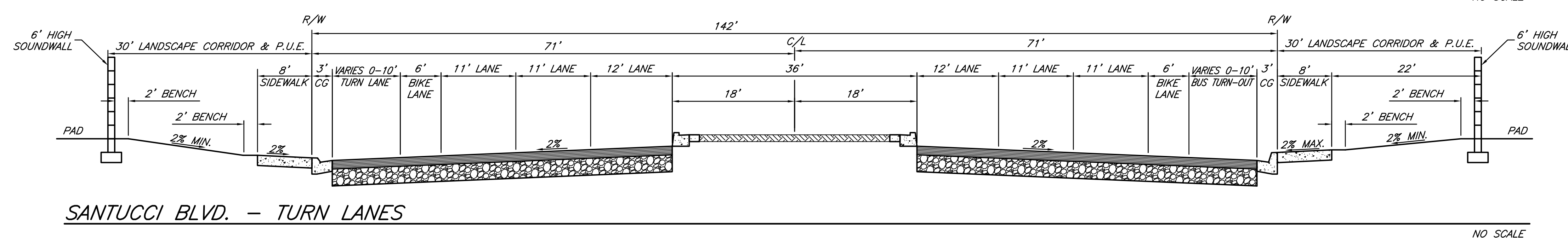
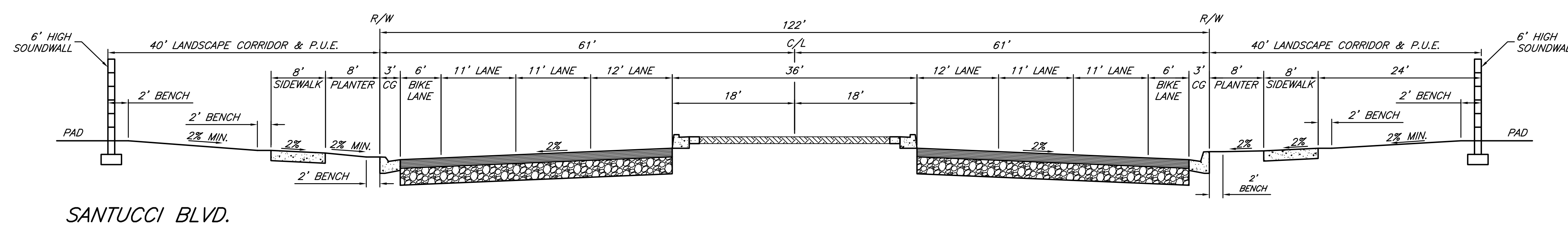
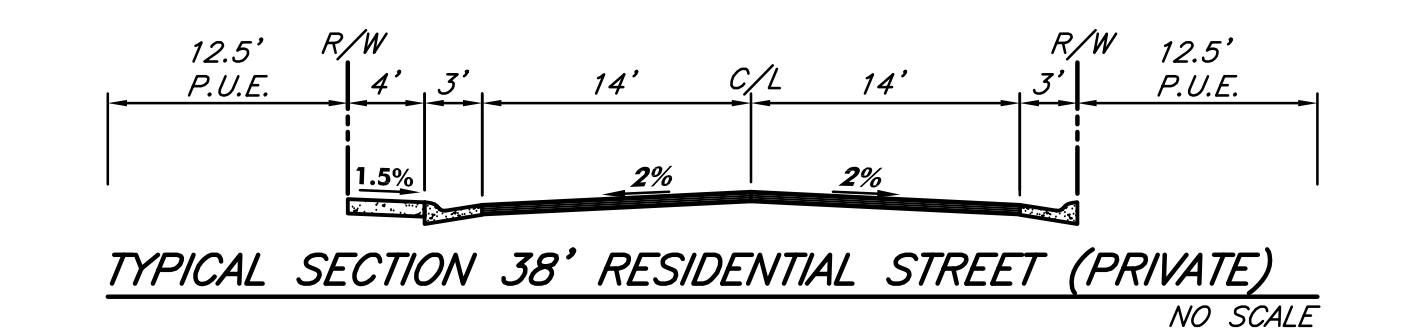
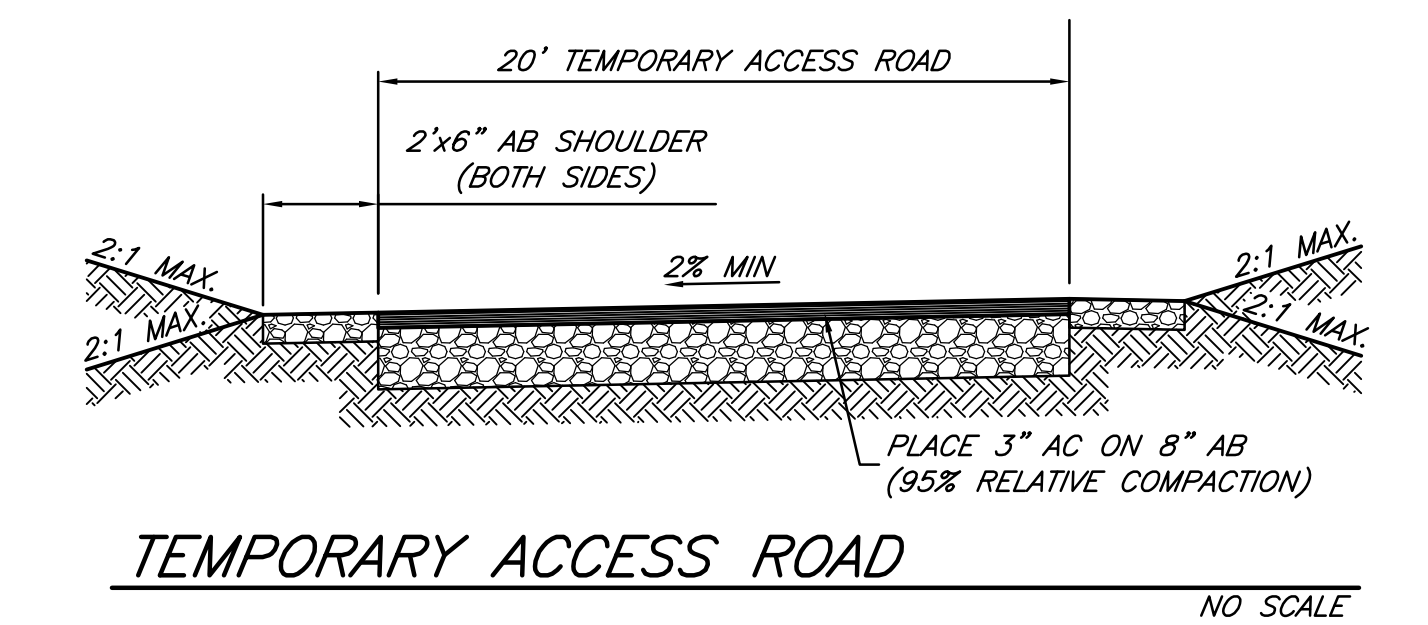
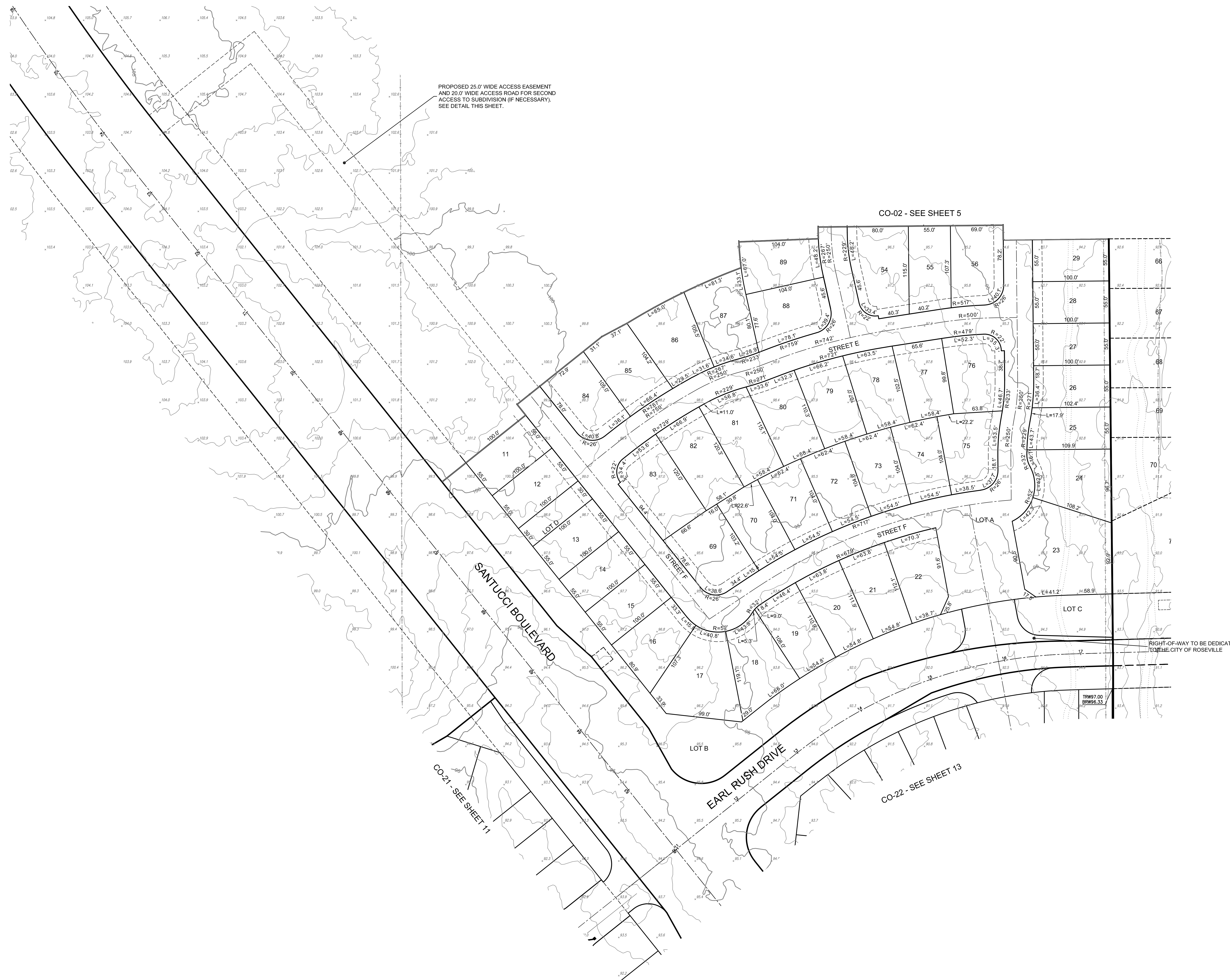
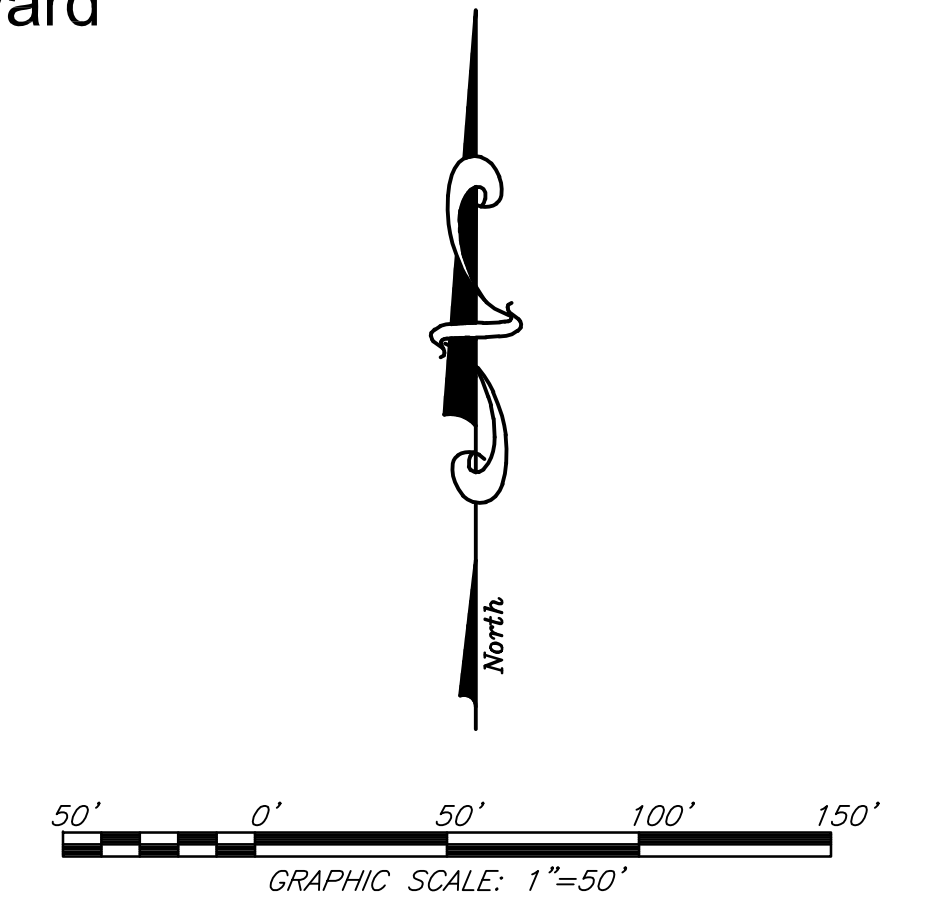

- NOTES: LETTERED LOTS**
- LOT A PUBLIC LANDSCAPE STRIP TO BE DEDICATED TO CITY OF ROSEVILLE
 - LOT B PUBLIC LANDSCAPE STRIP TO BE DEDICATED TO CITY OF ROSEVILLE
 - LOT C PUBLIC LANDSCAPE STRIP TO BE DEDICATED TO CITY OF ROSEVILLE

Tentative Subdivision Map No. 4 of The Villages at Sierra Vista:
VILLAGES CO-01, CO-02, CO-03, CO-20, CO-21 AND CO-22

A PORTION OF SECTIONS 35 AND 36, T. 11 N., R. 5 E., M.D.M.
 City of Roseville, State of California
 Scale 1" = 50' June 2021

Sheet 7 of 14

Project Address - 3871 Santucci Boulevard

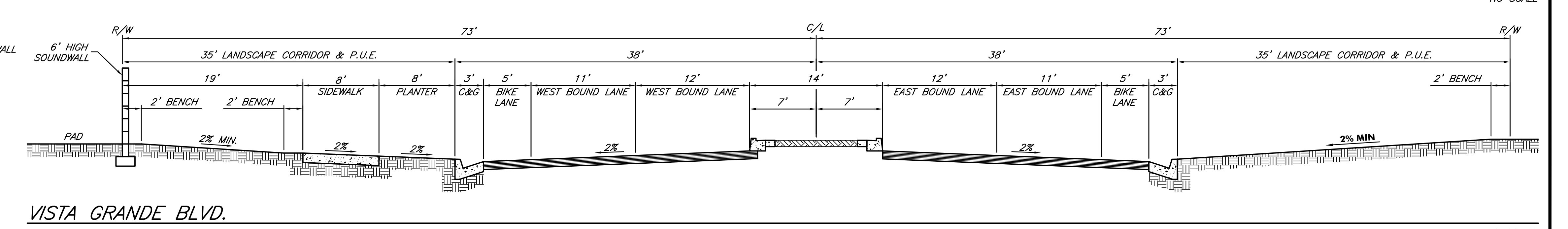
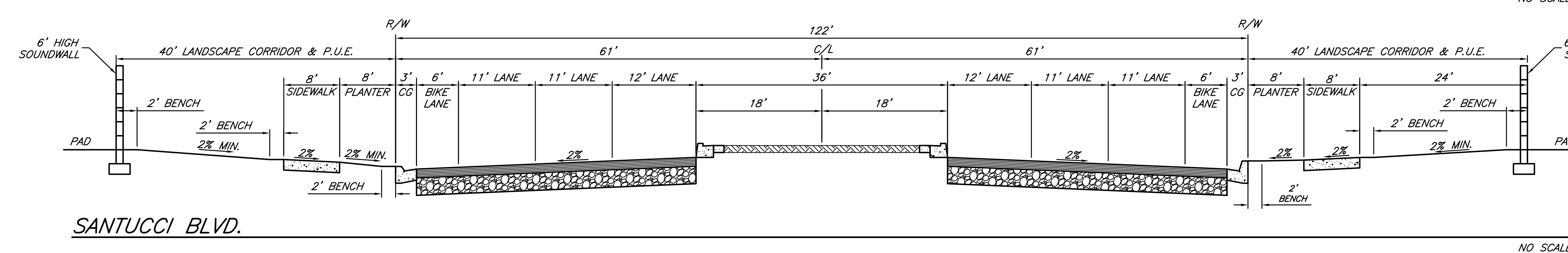
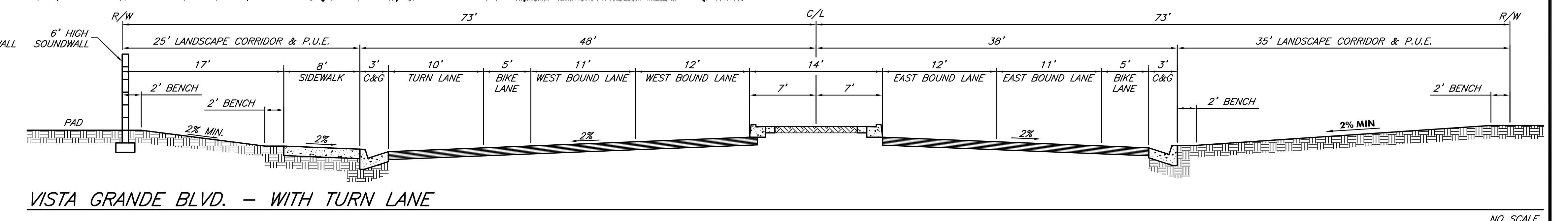
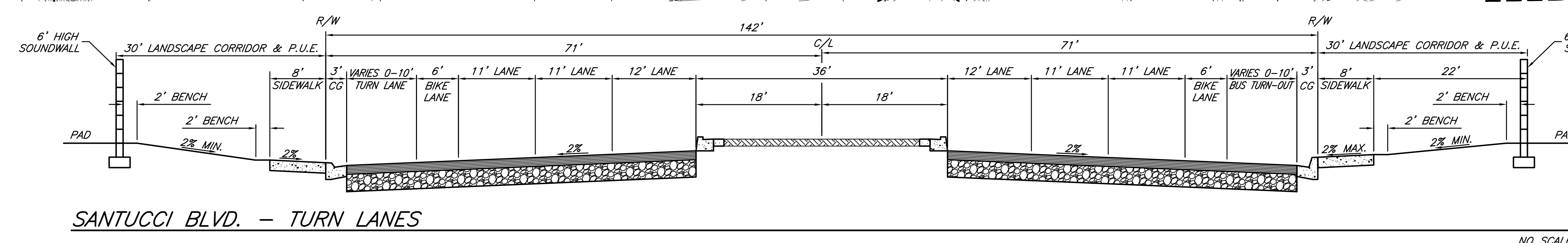
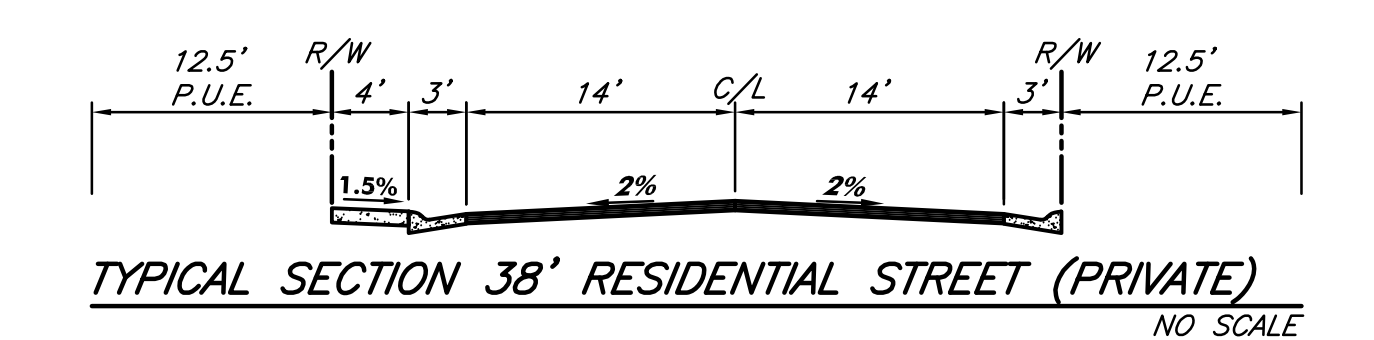
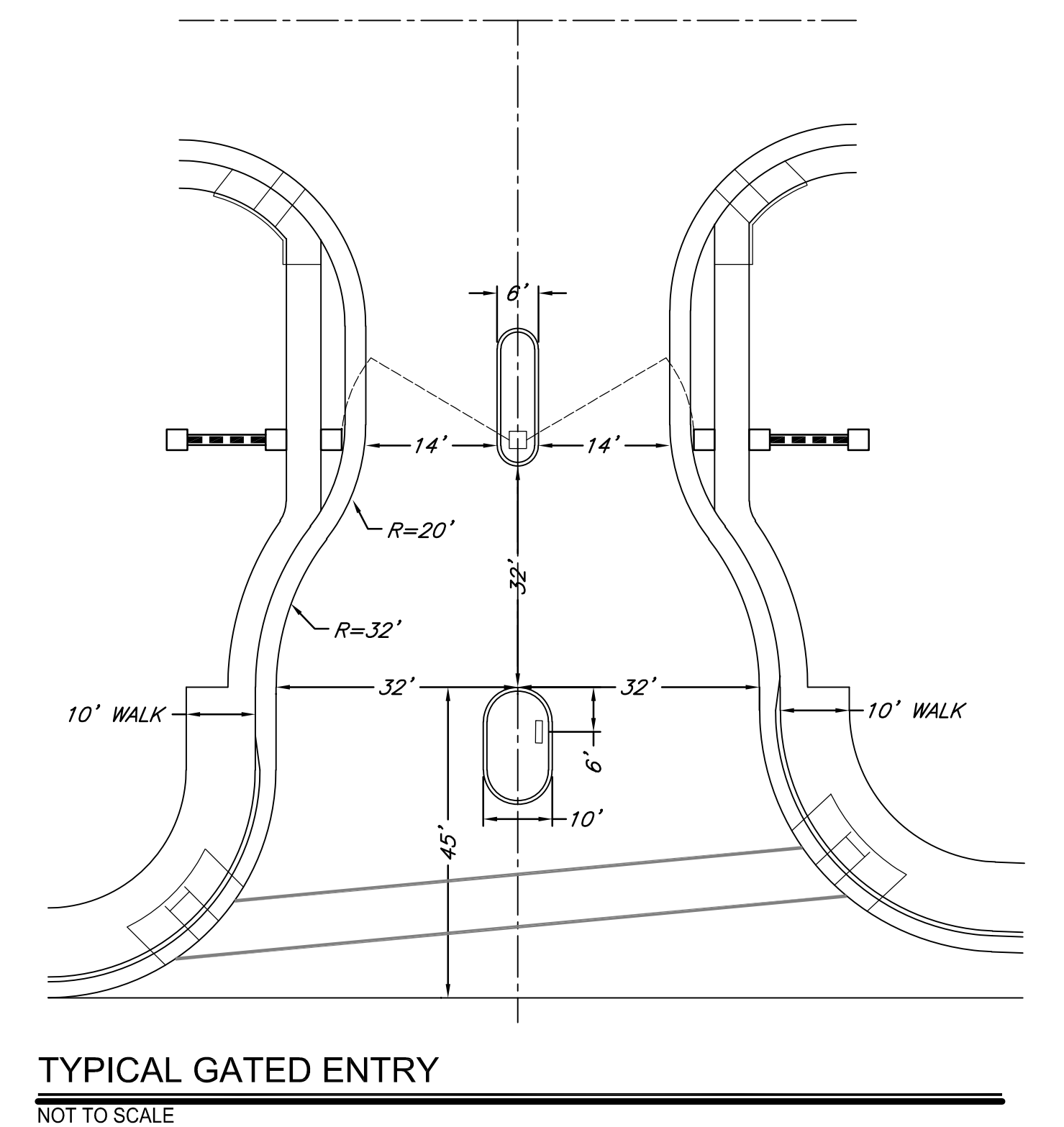
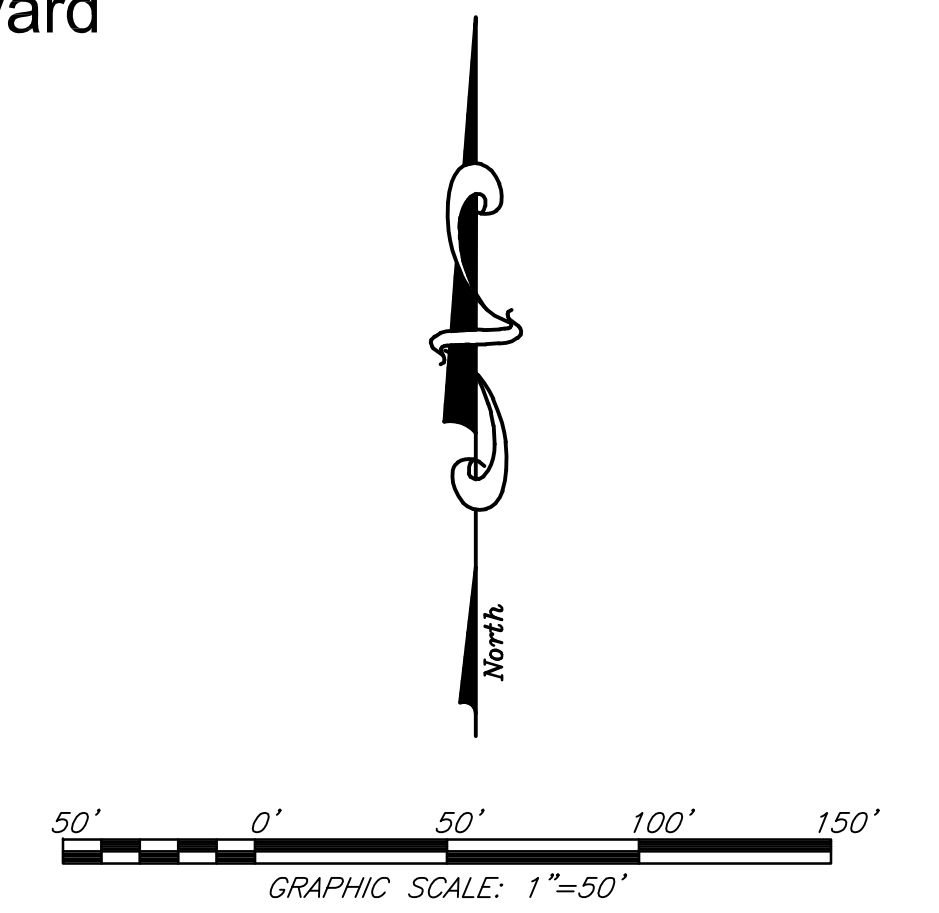

- NOTES: **LETTERED LOTS**
- LOT A PRIVATE STREET TO BE DEDICATED TO THE HOMEOWNERS ASSOCIATION
 - LOT B PUBLIC LANDSCAPE STRIP TO BE DEDICATED TO CITY OF ROSEVILLE
 - LOT C PUBLIC LANDSCAPE STRIP TO BE DEDICATED TO CITY OF ROSEVILLE

Tentative Subdivision Map No. 4 of The Villages at Sierra Vista:
VILLAGES CO-01, CO-02, CO-03, CO-20, CO-21 AND CO-22

A PORTION OF SECTIONS 35 AND 36, T. 11 N., R. 5 E., M.D.M.
City of Roseville, State of California
Scale 1" = 50' June 2021

Sheet 9 of 14

Project Address - 3871 Santucci Boulevard

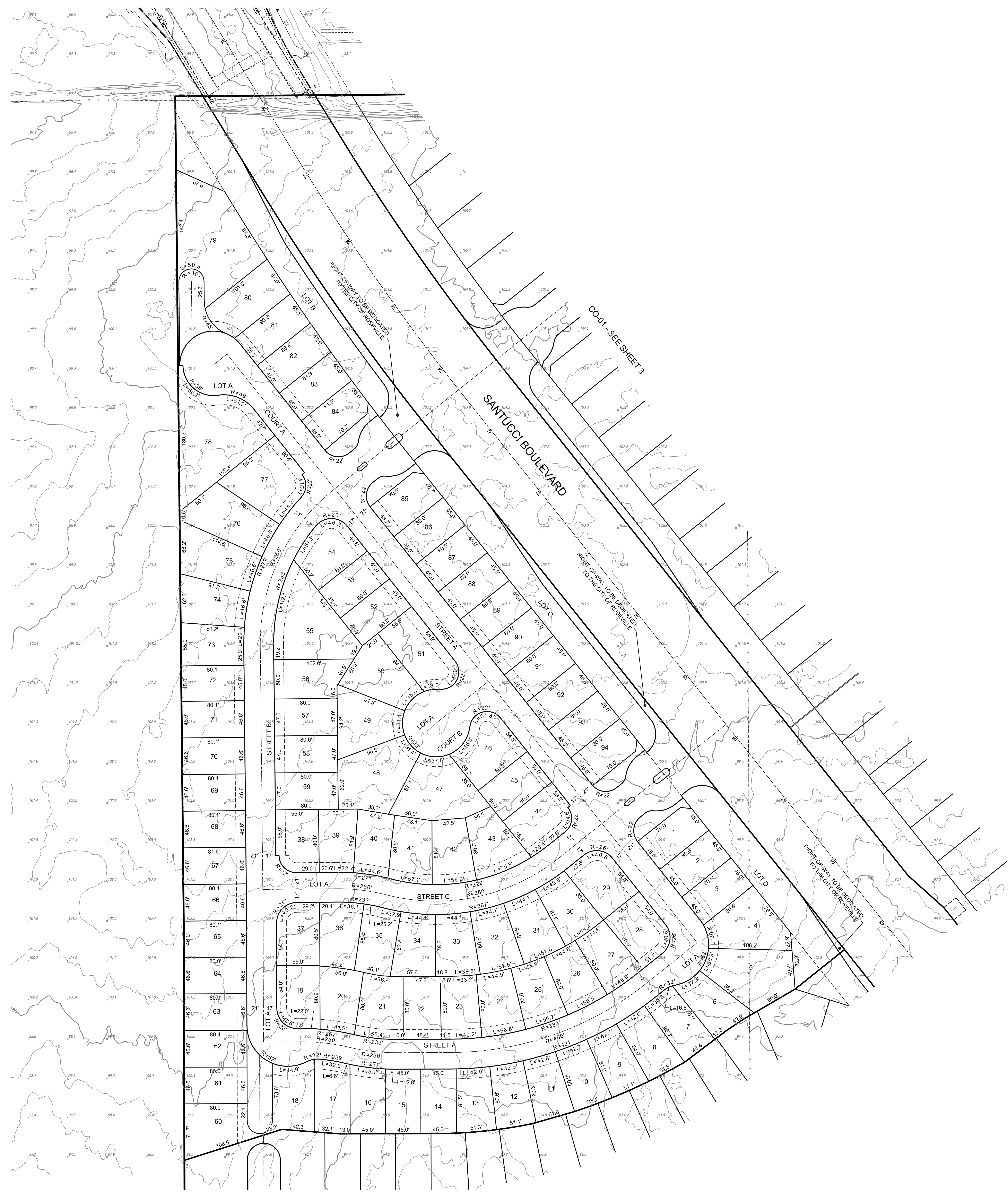

CO-21 - SEE SHEET 11

- NOTES: LETTERED LOTS**
- LOT A PRIVATE STREET TO BE DEDICATED TO THE HOMEOWNER'S ASSOCIATION
 - LOT B PUBLIC LANDSCAPE STRIP TO BE DEDICATED TO CITY OF ROSEVILLE
 - LOT C PUBLIC LANDSCAPE STRIP TO BE DEDICATED TO CITY OF ROSEVILLE
 - LOT D PUBLIC LANDSCAPE STRIP TO BE DEDICATED TO CITY OF ROSEVILLE

Tentative Subdivision Map - CO-20

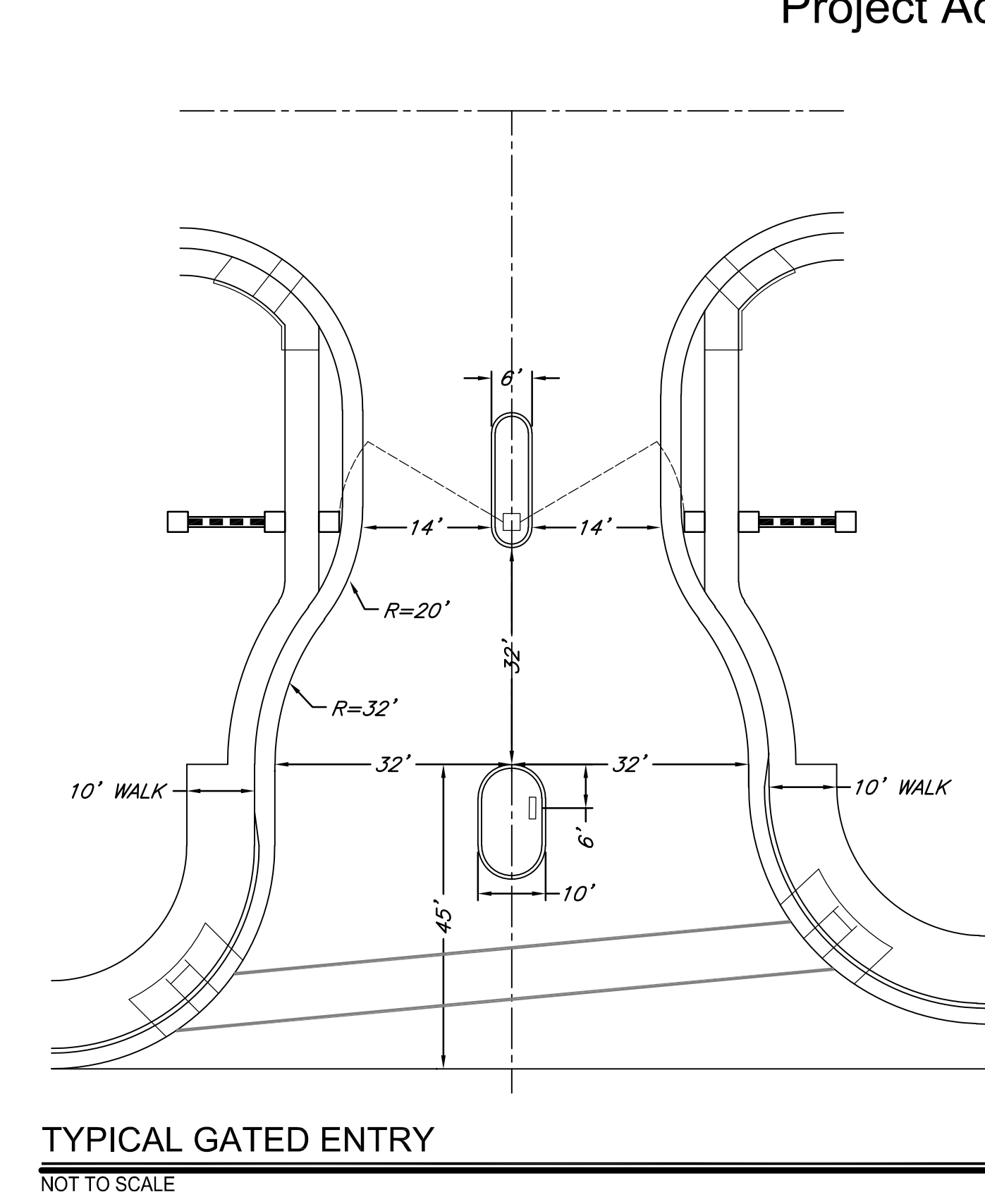

TYPICAL GATED ENTRY
NOT TO SCALE

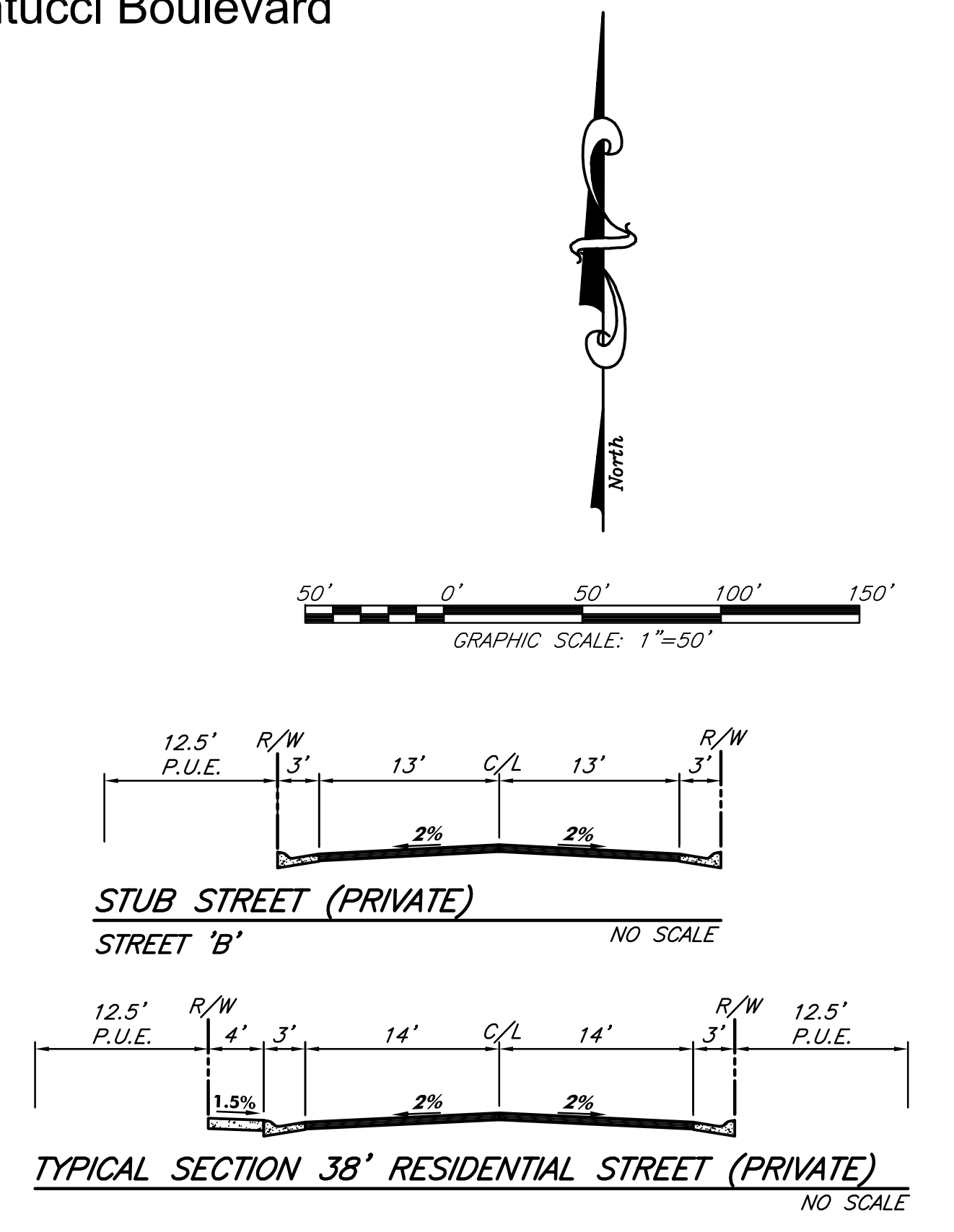

TYPICAL SECTION 38' RESIDENTIAL STREET (PRIVATE)
NO SCALE

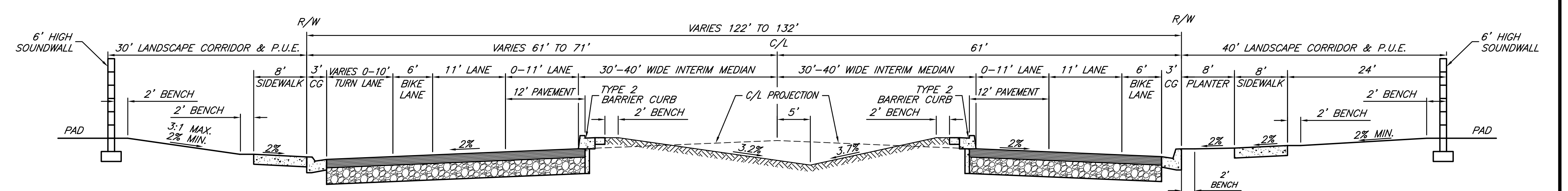

SANTUCCI BLVD. - INTERIM SECTION NORTH BOUNDARY
STA. 76+43.15 TO STA. 78+55.37
NO SCALE

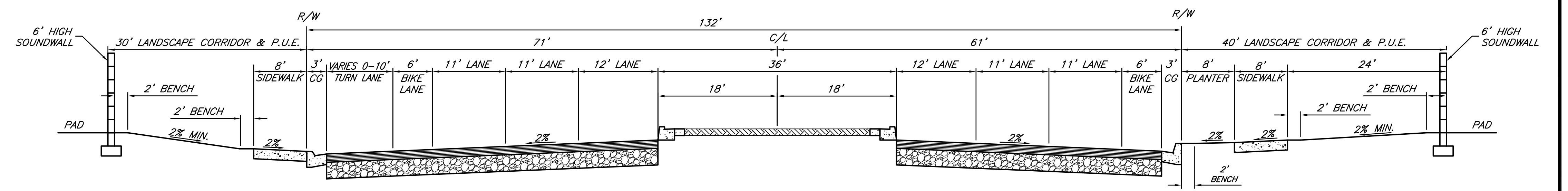

SANTUCCI BLVD. - TURN LANES LEFT
NO SCALE

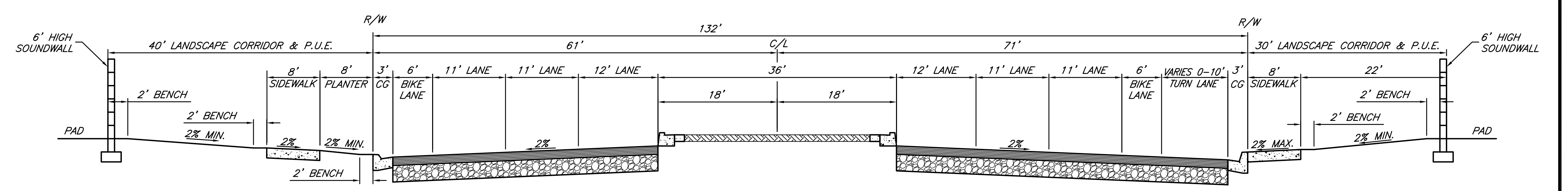

SANTUCCI BLVD. - TURN LANES RIGHT
NO SCALE

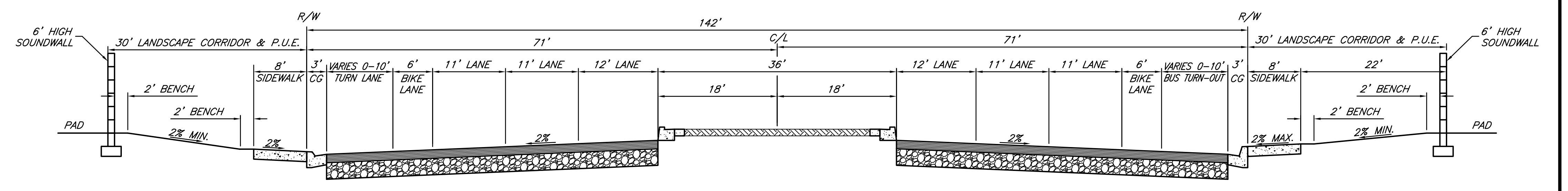

SANTUCCI BLVD. - TURN LANES
NO SCALE

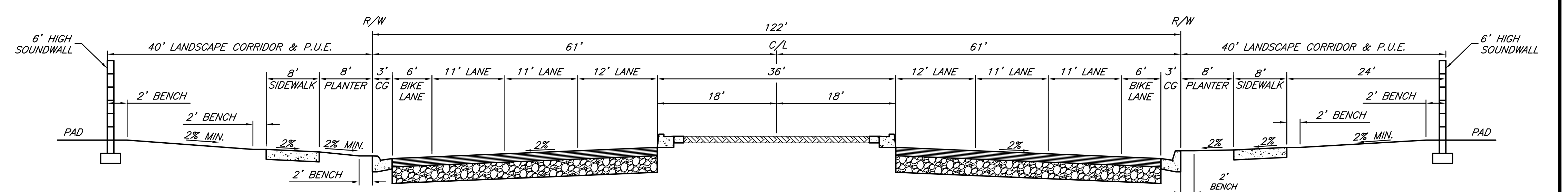

SANTUCCI BLVD.
NO SCALE

Tentative Subdivision Map No. 4 of The Villages at Sierra Vista:
VILLAGES CO-01, CO-02, CO-03, CO-20, CO-21 AND CO-22

A PORTION OF SECTIONS 35 AND 36, T. 11 N., R. 5 E., M.D.M.
 City of Roseville, State of California
 Scale 1" = 50'
 June 2021

Sheet 11 of 14

Project Address - 3871 Santucci Boulevard

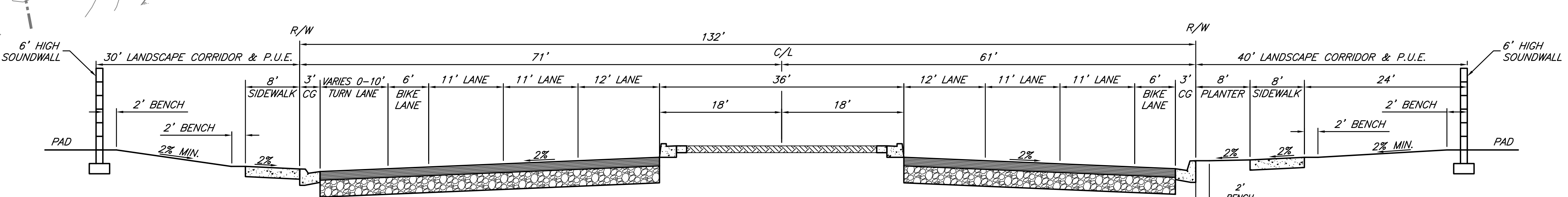
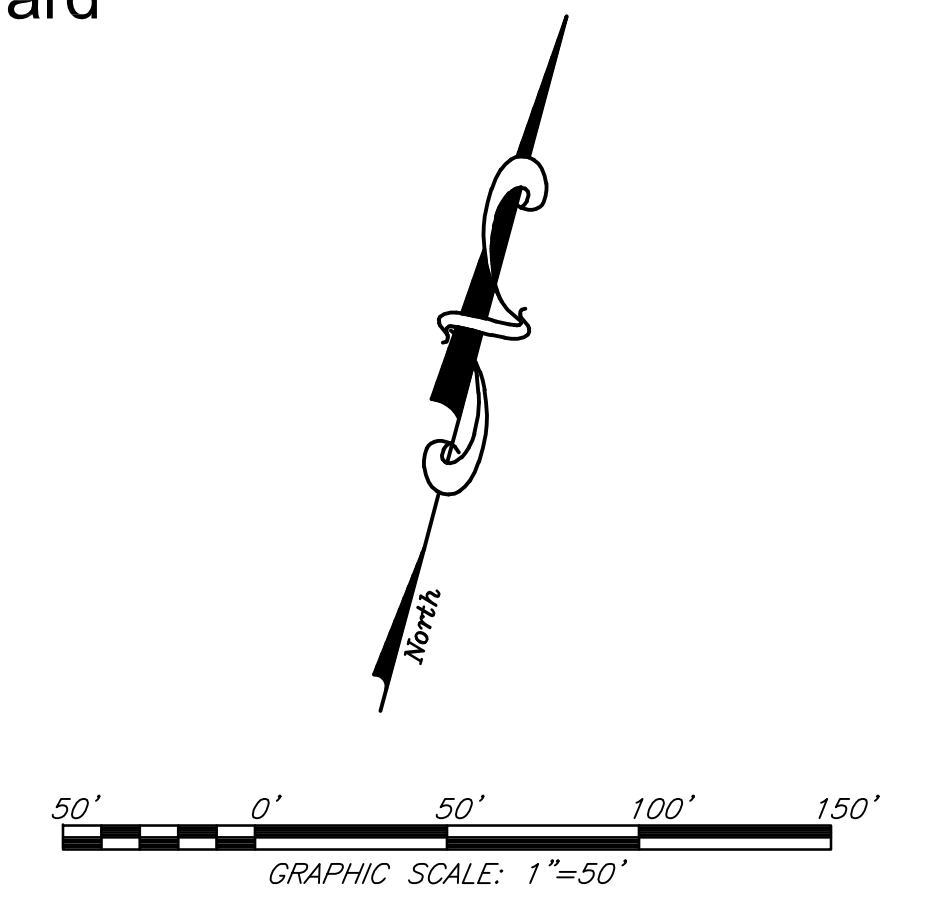

SANTUCCI BLVD. - TURN LANES LEFT

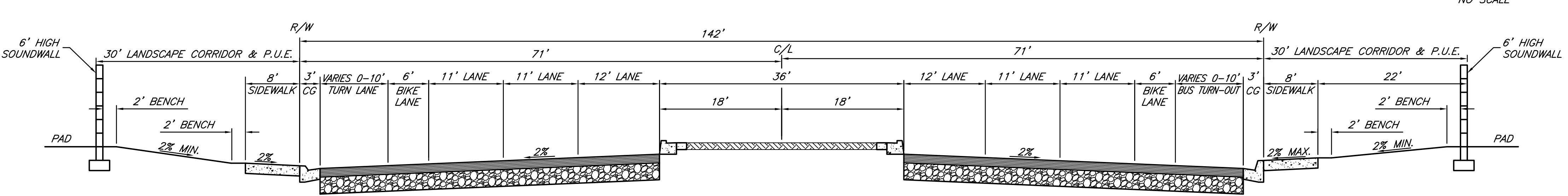

SANTUCCI BLVD. - TURN LANES

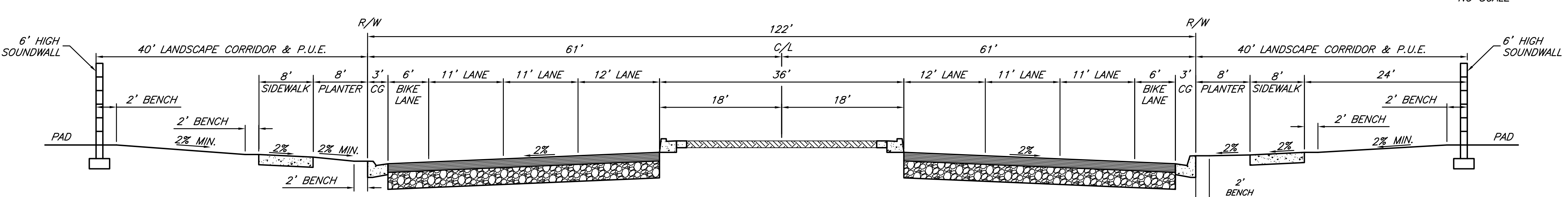

SANTUCCI BLVD.

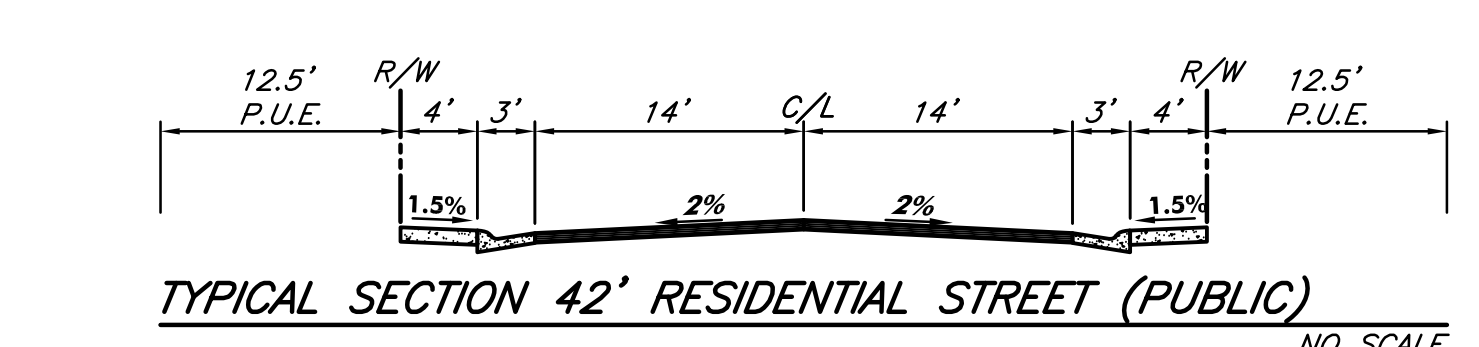

TYPICAL SECTION 42' RESIDENTIAL STREET (PUBLIC)

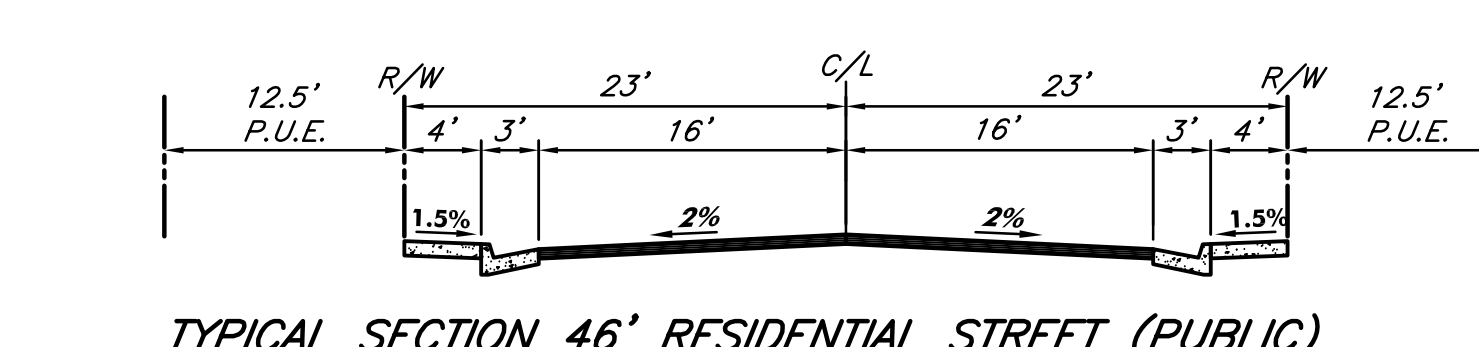

TYPICAL SECTION 46' RESIDENTIAL STREET (PUBLIC)

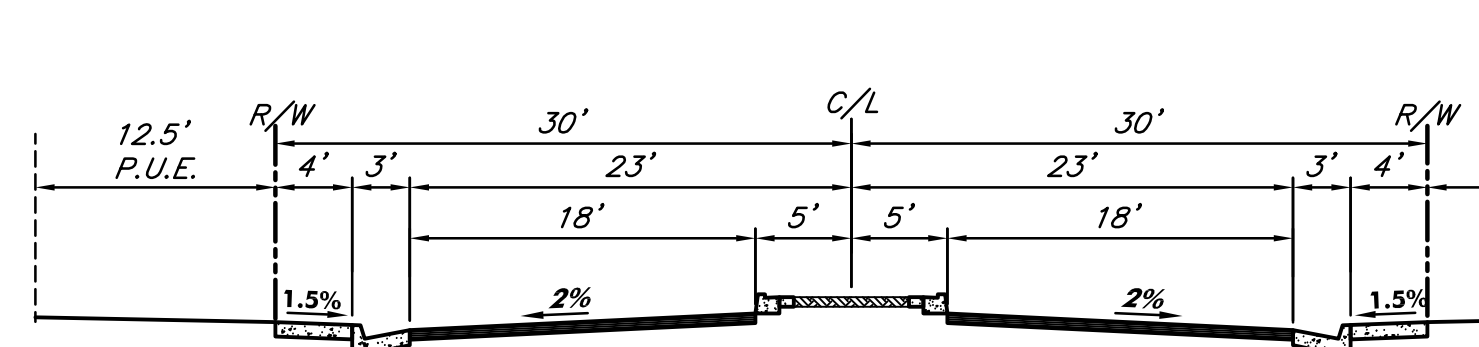

TYPICAL SECTION 30' ENTRANCE STREET (PUBLIC)

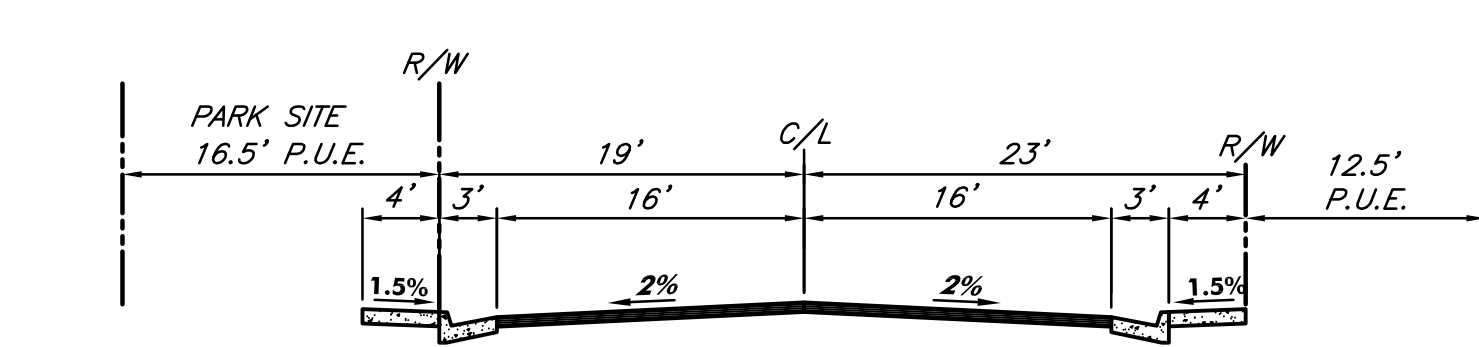

STREET 'G' ADJACENT TO PARK (PUBLIC)

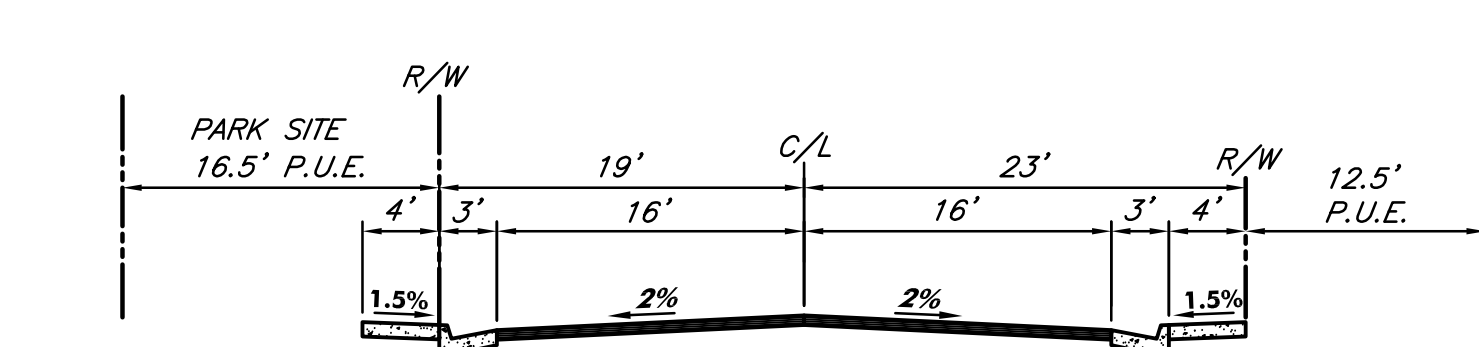

STREET 'B', 'D' & 'E' ADJACENT TO PARK (PUBLIC)

- NOTES: LETTERED LOTS
 LOT A PUBLIC LANDSCAPE STRIP TO BE DEDICATED TO CITY OF ROSEVILLE
 LOT B PUBLIC LANDSCAPE STRIP TO BE DEDICATED TO CITY OF ROSEVILLE
 LOT C PUBLIC LANDSCAPE STRIP TO BE DEDICATED TO CITY OF ROSEVILLE